

Dobbie fire boosters, manufactured right here in Australia, are accredited to AS2419.3:2012. In fact, Dobbie was the first company to have a booster approved under the 2012 Standard. The new style Dobbie fire booster was designed by Dobbie's team of fire specialists. With over 50 years combined expertise between them they developed the booster from concept through to production.

The result is a booster that not only conforms to the current Australian Standard but is also easy to install, efficient in the field and extremely cost competitive against the plethora of imported product. Our ongoing QA commitment demands fire boosters are individually tested ensuring a quality product with problem free performance. As Dobbie boosters are made here in Australia, it is possible to have them re-configured for specialty applications up to Class 21. This makes them suitable for most high-rise commercial buildings.

Dobbie fire boosters come in a range of sizes and configurations, including 80mm Single; 100mm Dual; & 150mm Quad. All boosters have R/G outlet connections (the single booster additionally has 65mm BSP (f)) and are available with couplings to suit all state fire authorities.

**Dimensions & Installation Details**

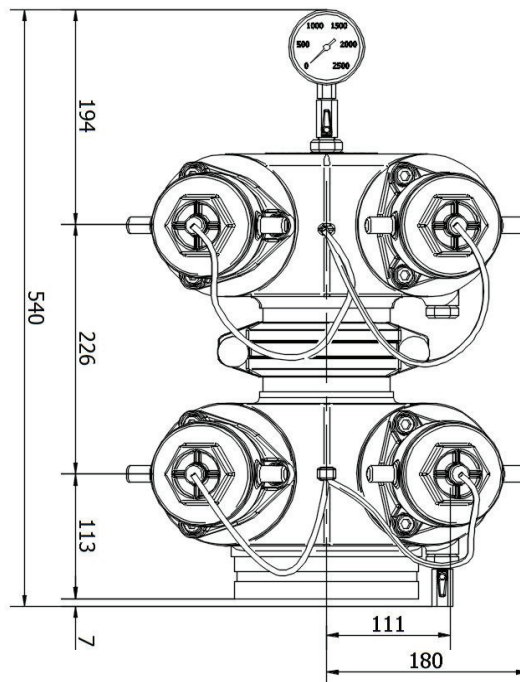
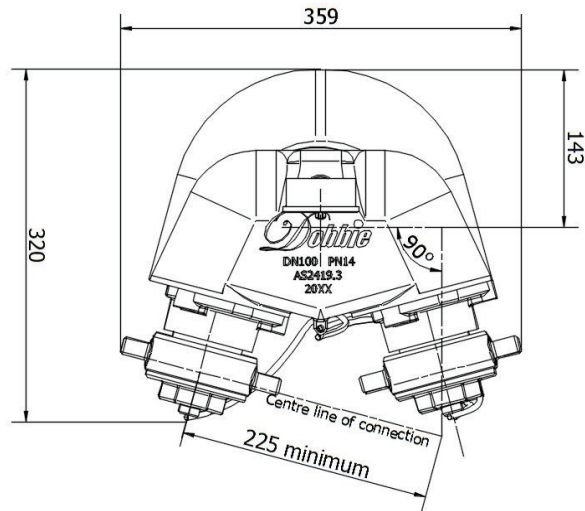

**Installation**

Height to centre of fire brigade connections to be between 750-1200mm above Finished Ground Level.  
 Minimum clearance of 225mm from the centre of fire brigade connections to other obstructions.  
 See AS2419.1 for further installation details.

**Product Codes**

Quad Booster - Bottom Outlet  
 Storz: B150QSTZRGB  
 B.I.C.: B150QBICRGB  
 CFA: B150QCFARGB  
 SAFB: B150QSAFBRGB  
 QRT: B150QQRTRGB

**Materials**

Body: Ductile Iron (FBE Coated)  
 Check Assembly: Stainless Steel  
 Fire Brigade Connection: QRT - Gunmetal  
 Cap: PP RED  
 Gauge: Stainless Steel (GF)  
 Roll Groove Coupling: HDG - UL/FM Approved

